



**SIDDHARTH INSTITUTE OF ENGINEERING & TECHNOLOGY:: PUTTUR
(AUTONOMOUS)**

Siddharth Nagar, Narayanavanam Road – 517583

QUESTION BANK (DESCRIPTIVE)

Subject with Code: Advanced Structural Analysis (19CE1001)

Course & Branch: M.Tech – SE

Year & SEM: I M.Tech & I-Sem

Indeterminacy

Regulation: R19

- What are the differences between static and kinematic indeterminacies? Explain them with examples.
 - Calculate the degree of redundancy plane frame as shown in Figure 1.1

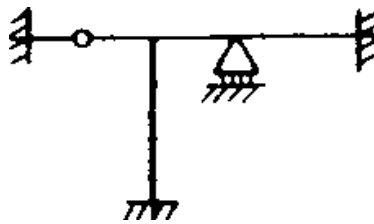

Figure 1.1

- Determine the kinematic indeterminacies of the frame & beams in Figure 1.2

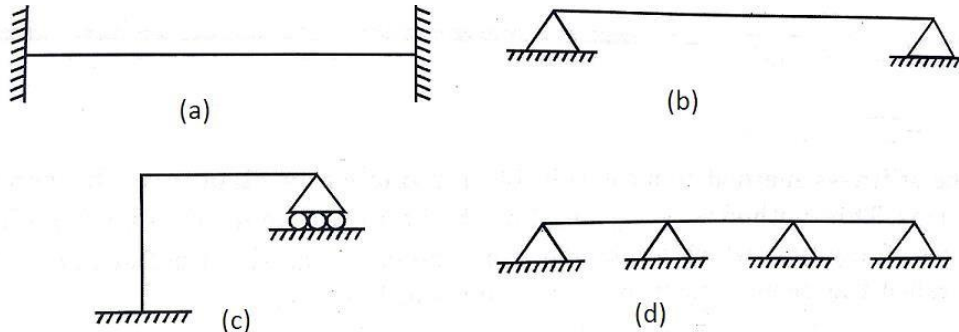

Figure 1.2

- Differentiate between DOF and DOR.
 - Calculate the degree of redundancy and degree of freedom for Figure 1.3

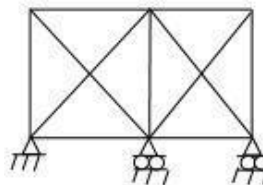

Figure 1.3

4. a) Explain the classification of structures with examples.
 b) Derive the relation between flexible and stiffness matrix
5. Determine the degree of static indeterminacy of the following Figure 1.4(a) and 1.4(b)

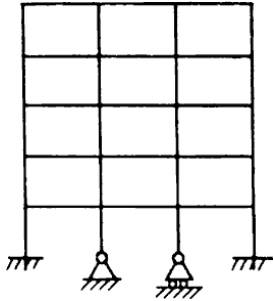

Figure 1.4(a)

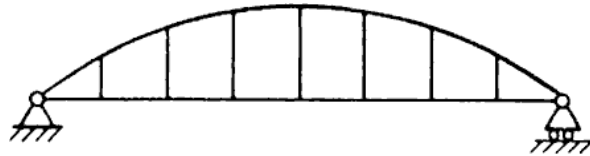

Figure 1.4(b)

6. a) What is static and kinematic indeterminacy?
 b) What is degree of static and kinematic indeterminacy of the following frame shown in Figure 1.5(a) and 1.5(b)

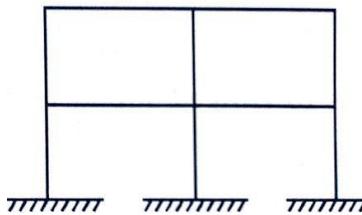

Figure 1.5(a)

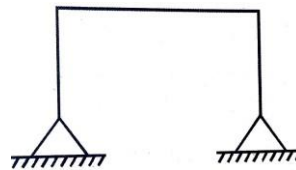

Figure 1.5(b)

7. a) Determine the degree of static indeterminacy of the rigid jointed building frame shown in Figure 1.6(a)
 b) Determine the degree of static indeterminacy of the pin jointed space frame shown in Figure 1.6(b)

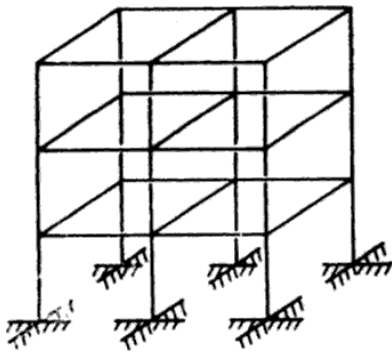

Figure 1.6(a)

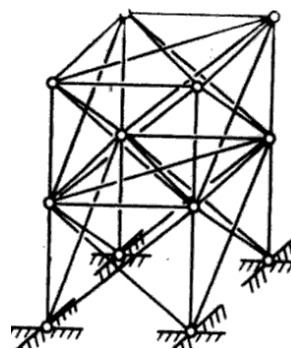

Figure 1.6(b)

8. Determine degree of redundancy for the following beam shown in Figure 1.7

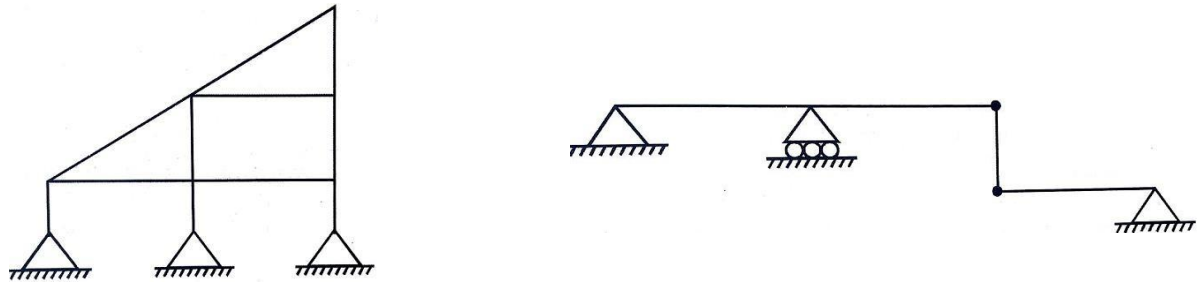

Figure 1.7

9. Determine degree of freedom for the following beam shown in Figure 1.8

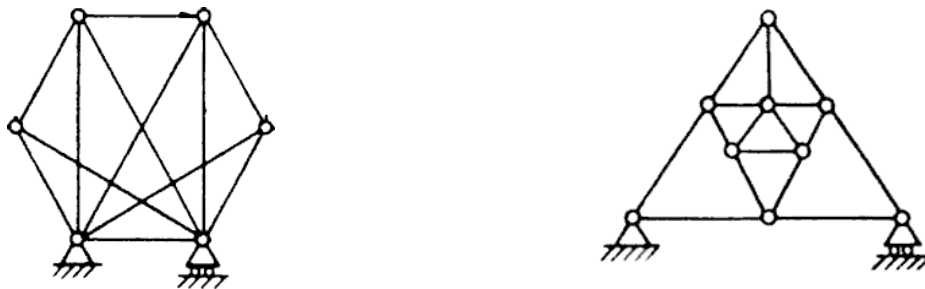

Figure 1.8

10. Calculate the D_s and D_k for the following



Figure 1.9

UNIT-II

Introduction To Matrix Methods Of Analysis

1. Explain briefly about flexibility matrix method of Analysis
2. a) Find the flexibility matrix of the cantilever shown in Figure 2.1 EI is constant.

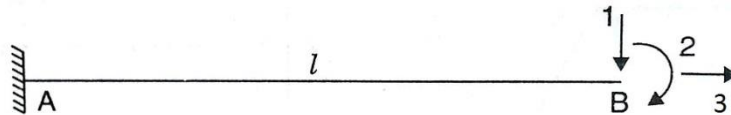

Figure 2.1

- b) For the simply supported beam shown in Figure 2.2. Develop the flexibility matrix

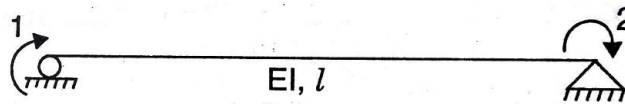

Figure 2.2

3. Develop the flexibility matrix for the cantilever with coordinates as shown in Figure 2.3

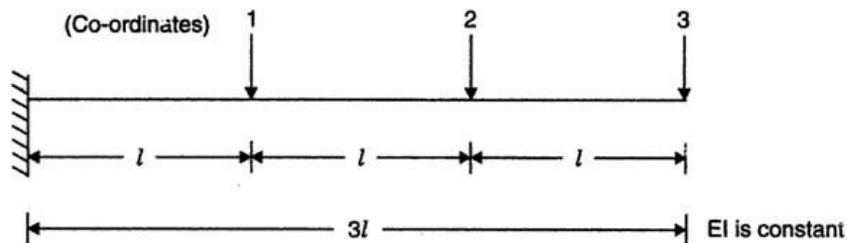

Figure 2.3

4. Develop the flexibility matrix for the cantilever beam with reference to the coordinates shown in Figure 2.4

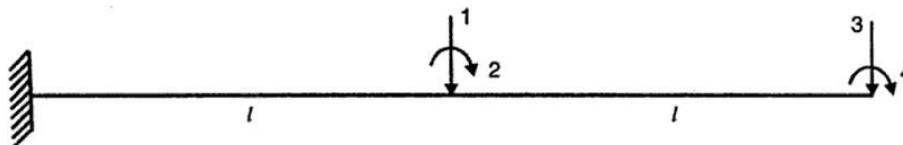

Figure 2.4

5. Develop the flexibility matrix for structure with coordinates shown in Figure 2.5 EI is constant

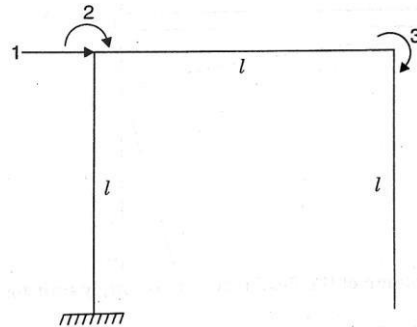

Figure 2.5

6. Explain briefly about Stiffness matrix method of Analysis
7. Develop the stiffness matrix for the end-loaded prismatic member AB with reference to the Coordinates shown in Figure 2.6

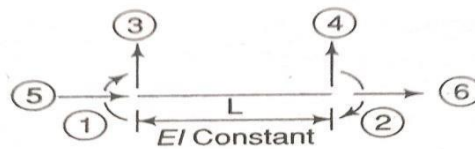

Figure 2.6

8. a) Develop the stiffness matrix of the beam as shown in Figure 2.7 with 2 coordinate system

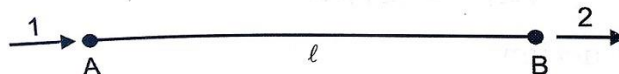

Figure 2.7

- b) Develop the stiffness matrix of the beam as shown in Figure 2.8 with respect to the 2 degree of freedom given

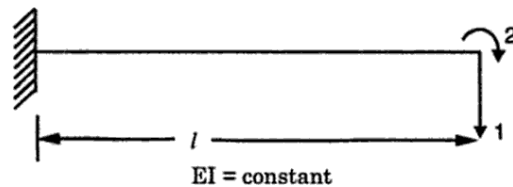
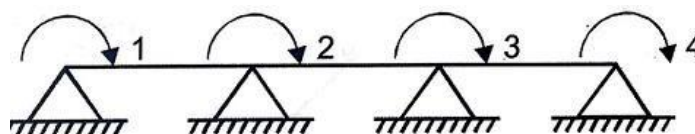

Figure 2.8

- c) Determine the stiffness matrix of the beam as shown in Figure 2.9



9. a) Develop the stiffness matrix of the beam as shown in Figure 2.10 with respect to the 4 degree of freedom given

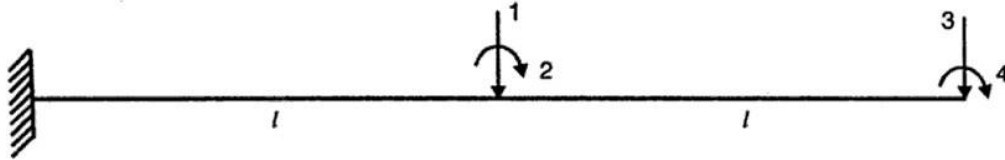

Figure 2.10

- b) Generate the stiffness matrix for the structure with coordinates as shown in Figure 2.11

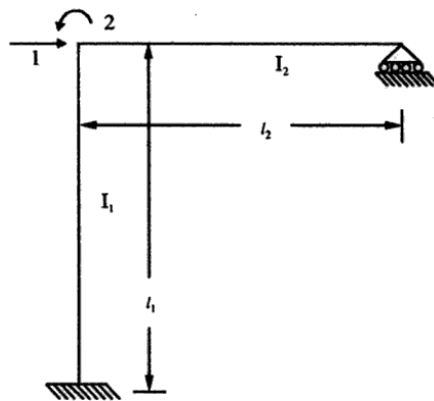

Figure 2.11

10. Generate the stiffness matrix for the structure with coordinate as shown in Figure 2.12 EI is constant

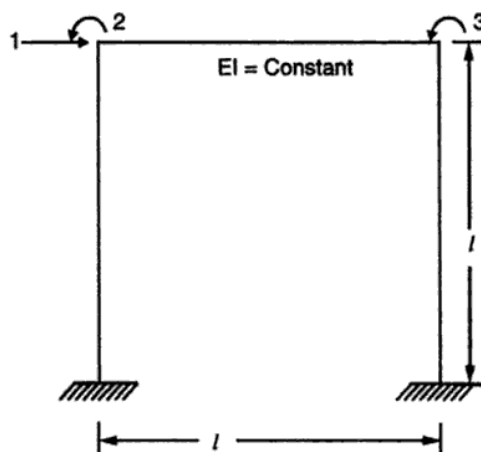

Figure 2.12

UNIT-III**Analysis of Continuous Beams & Analysis of 2D Pin Jointed Trusses**

1. Analyze the continuous beam shown in Figure 3.1 by displacement method EI is constant

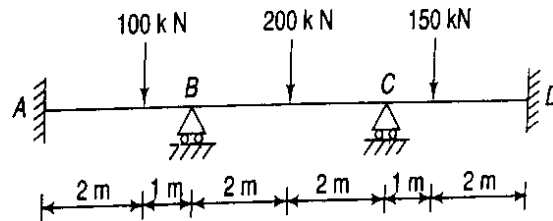

Figure 3.1

2. Analyze the continuous beam shown in Figure 3.2 by displacement method

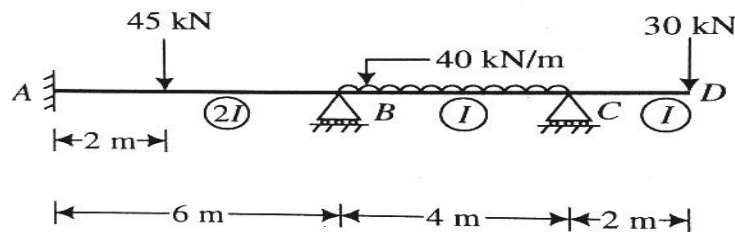

Figure 3.2

3. Analyze the continuous beam shown in Figure 3.3 by Flexibility method. The downward settlement of supports B and C in kN-m are $1500/EI$ and $750/EI$.

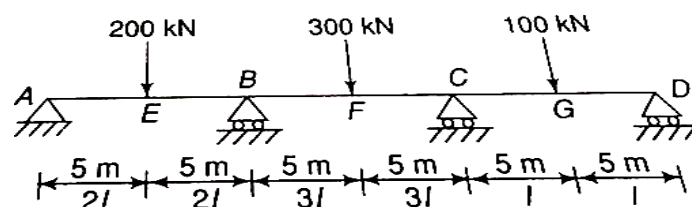

Figure 3.3

4. Analyze the continuous beam shown in Figure 3.4, if the downward settlement of supports B and C are 12 mm and 6 mm respectively. Given $EI = 20 \times 10^{12}$ N-mm². Use Flexibility matrix method

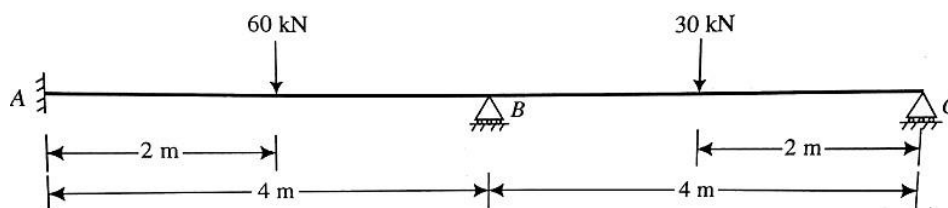

Figure 3.4

5. Analysis a continuous beam as shown in Figure 3.5 if downward settlement B & C is $kN\cdot m$ units are $200/EI$ and $100/EI$ respectively. Using Stiffness matrix method

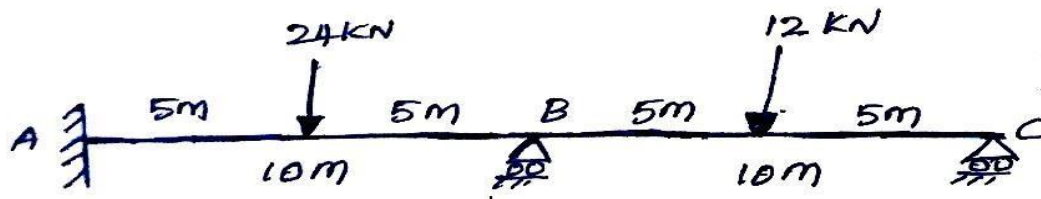

Figure 3.5

6. Using flexibility matrix method for the beam shown in Figure 3.6 and draw shear force and bending moment diagrams, EI is Constant

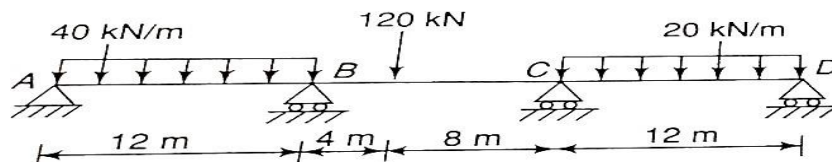

Figure 3.6

7. Develop the flexibility matrix for the pin-jointed plane frame with reference to coordinates 1 & 2 shown in Figure 3.7 The numbers in parentheses are the cross-sectional areas of the members in mm^2

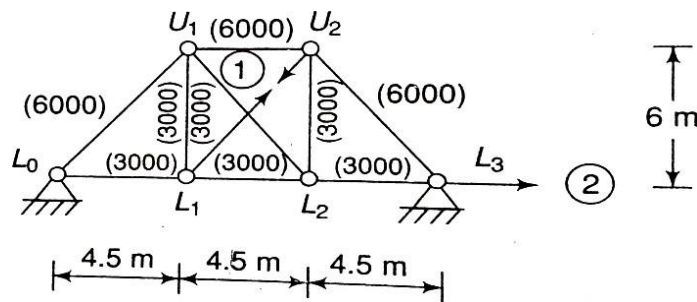

Figure 3.7

8. Figure 3.8 shows a jip-Crane carrying vertical load of 10kN at A. Determine the deflection of Joint A. Hence calculate the forces in members AB & AC. The cross-sectional area in mm^2 . Take $E=200kN\cdot mm^2$.

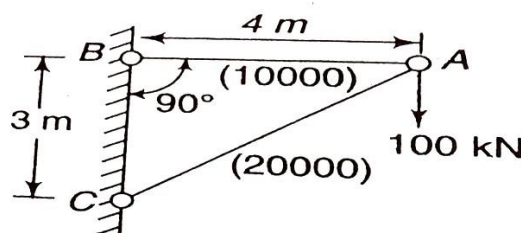

Figure 3.8

9. Analyze the pin-jointed structure shown in Figure 3.9 by flexibility matrix method. The area of each member is 200mm^2 . Take $E=200\text{KN/mm}^2$

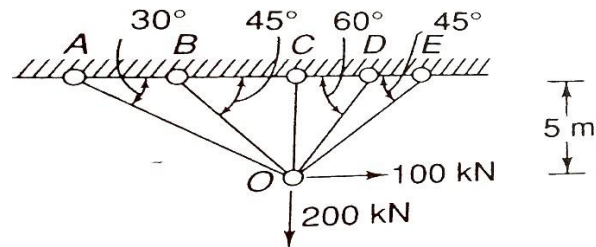

Figure 3.9

10. Analyze the pin-jointed structure shown in Figure 3.10 by Stiffness matrix method. The area of each member is 1000mm^2 . Take $E=200\text{KN/mm}^2$

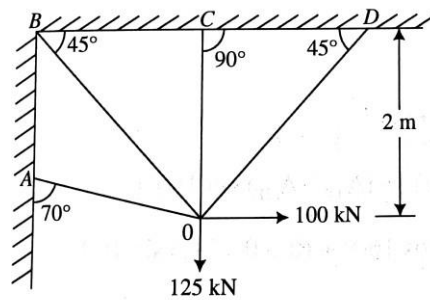
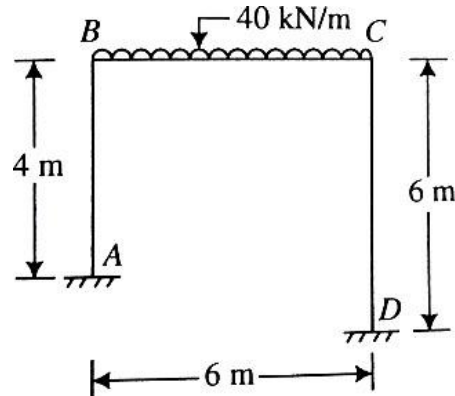

Figure 3.10

UNIT – IV
Analysis of 2D Portal Frames

1. Analyze the rigid jointed plane frame shown in Figure 4.1 by flexibility matrix method. EI is constant throughout



2. Analyze the portal frame ABCD shown in figure 4.2 using Force Method

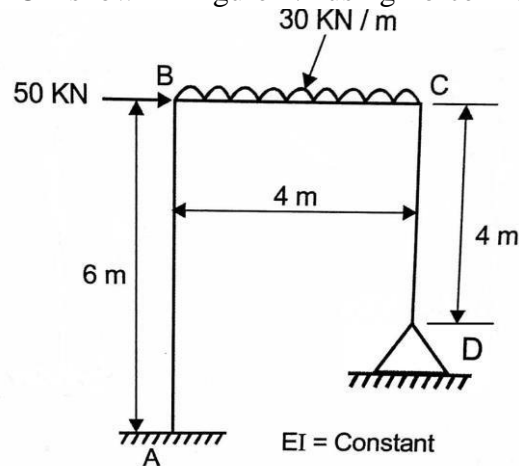

3. Analyze the frame shown in figure 4.23 by force method.

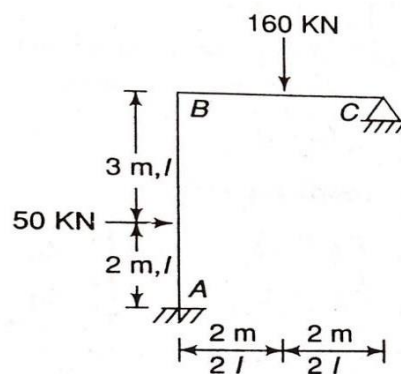

4. Analyze the portal frame shown in figure 4.4 by displacement method

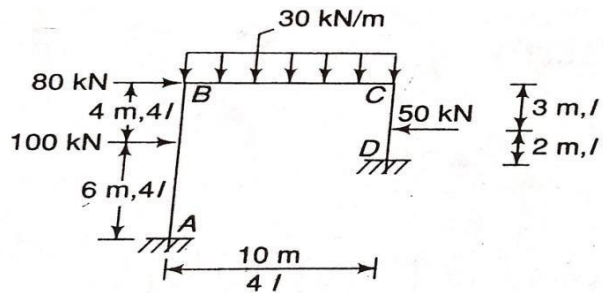

5. Analyze the frame shown in figure 4.5 by displacement method.

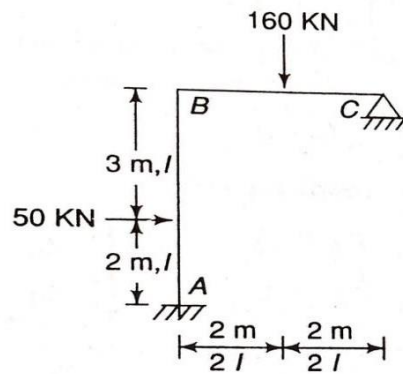

6. Analyze the portal frame shown in figure 4.6 by force method.

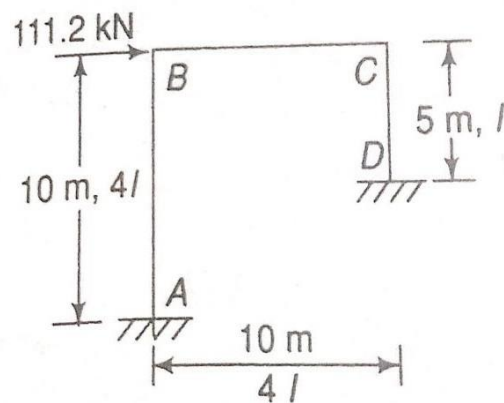

7. Determine the stiffness matrix for the portal frame shown in figure 4.7

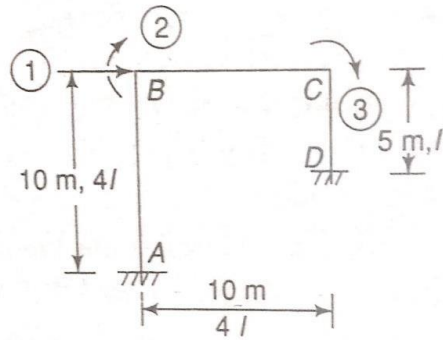

8. Analyze the portal frame shown in figure 4.8 by flexibility method.

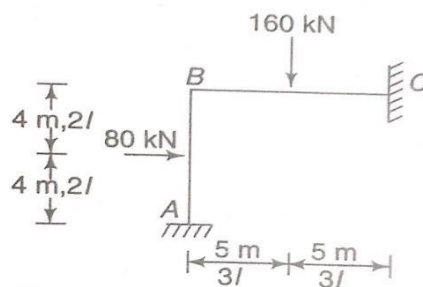

9. Calculate the force matrix and also draw the bending moment diagram for the following frame shown in figure 4.9

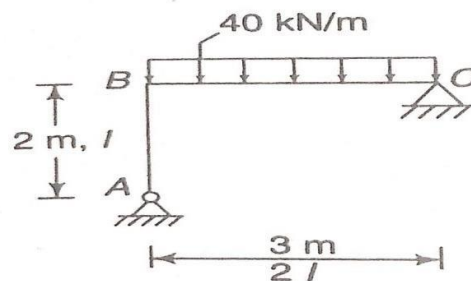

10. Calculate the displacement matrix for the following frame shown in figure 4.10. And also draw the bending moment diagram.

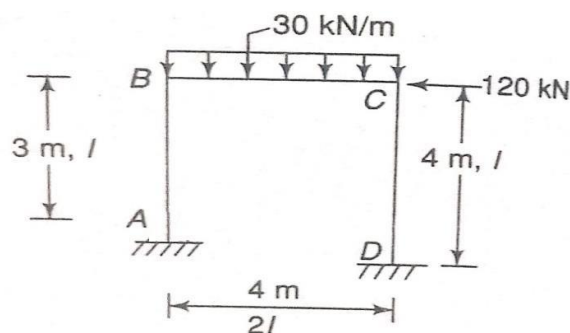

UNIT – V
Solution Techniques

1. A system of linear algebraic equations is given below. Obtain the solution by Cholesky method.

$$\begin{aligned}x+2y-3z &= 7 \\3x+2y+2z &=-5 \\4x - y+5z &=5\end{aligned}$$

2. Solve the following system of equations using Gauss elimination method.

$$\begin{aligned}-4x+ y + 10z &=21 \\5x - y + z &= 14 \\4x+ 6y + 7z &=12\end{aligned}$$

3. List and explain the direct methods for solving linear equations.
4. Determine the solution by using Gauss elimination method.

$$\begin{aligned}2x_1 - 2x_2 + 4x_3 &= -3 \\2x_1 + 3x_2 + 2x_3 &= 5 \\-x_1 + x_2 - x_3 &= 1\end{aligned}$$

5. Explain briefly about
a. Cholesky Method
b. Band Matrix and Semi band width
6. Explain briefly about
a. Gauss elimination method.
b. Solution of linear simultaneous equations.
7. Explain briefly about
a. Matrix inversion method.
b. Static Condensation
8. Explain briefly about
a. Frontal solution technique.
b. Direct inversion method.
9. Obtain the solutions of the following system of simultaneous equation by method of matrix inversion.

$$\begin{aligned}2x_1 + 6x_2 + 2x_3 + 4x_4 &= 40 \\6x_1 + 3x_2 - 2x_3 - 3x_4 &= -1 \\2x_1 - 2x_2 + 5x_3 - x_4 &= 2 \\4x_1 - 3x_2 - x_3 + 4x_4 &= 9\end{aligned}$$

10. Explain briefly about Frontal solution technique and static condensation